

where A_A, A_B , etc. = area of heat flow path, ft²

U_A, U_B , etc. = transmission coefficients of the respective paths

R_A, R_B , etc. = thermal resistances of the respective paths

A_t = total area being considered ($A_A + A_B + \dots + A_n$), ft²

Such analyses are especially important when the various paths have significantly different heat flow characteristics, or when the paths involve large percentages of the total wall.

A thermal bridge occurs when a material or object of relatively high thermal conductivity penetrates a material of relatively low thermal conductivity, increasing the rate of heat flow at the penetration or "bridge." Thermal bridges not only reduce energy efficiency, but can cause condensation as well. Thermal bridges may be taken into account in different ways. The wall shown in *Fig. 8-21* has thermal bridges where the wood studs interrupt the layer of insulation. The parallel-path method of calculation is used for such non-metallic bridges, where the path at the stud is path A and the path at the insulation is path B. The calculations show that the average U value for the wall is 6% higher than the U value at the insulation.

The wall shown in *Fig. 8-22* has a thermal bridge at the metal tie. Metallic bridges are considered using the parallel-zone method, where a slightly larger area is assumed to be affected than just the actual area of the metal itself (zone A). The American Society for Heating, Refrigeration and Air Conditioning Engineers (ASHRAE) *Handbook of Fundamentals* prescribes a method for determining the size and shape of each zone. In the case of a metal beam, the surface shape of zone A would be a strip of width W centered on the beam. Since the metal tie in *Fig. 8-22* is of circular wire, zone A is a circle of diameter W , which is calculated from the equation

$$W = m + 2d \quad (8.7)$$

where W = width or diameter of the zone, in.

m = width or diameter of the metal path, in.

d = distance from the panel surface to the metal, in. (but not less than 0.5 in.)

The larger of the two values calculated for W at each surface should be used. *Figure 8-23* shows that the effect of the metal tie is considerably less in an uninsulated cavity wall, because as the R value of the material which the metal bridge penetrates decreases, the percent of heat loss due to thermal bridging also decreases. As the distance between the face of the wall and the edge of the metal increases, however, the area of the affected zone increases. *Figure 8-24* illustrates this phenomenon. Only the web thickness of the metal stud is considered in calculating the area of the zone. The 1⁵/₈-in. stud flange is relatively thin compared to the wall section, and therefore does not significantly affect the average thermal performance of the system. Its distance from the exterior surface is the thickness of the masonry, plus the air space, plus the sheathing thickness. For quick calculations, the table in *Fig. 8-25* gives effective R values for metal stud walls used as backing for masonry veneers. The closer the stud spacing, the more the thermal bridging affects overall wall performance. With 4-in. studs at 16 in. on center, the wall actually provides only half the thermal resistance that the R value of the insulation indicates.

For estimating a building's heating and cooling requirements, U values are used in heat-loss and heat-gain calculations with specific outdoor design temperatures for winter and summer. These calculations (like the laboratory

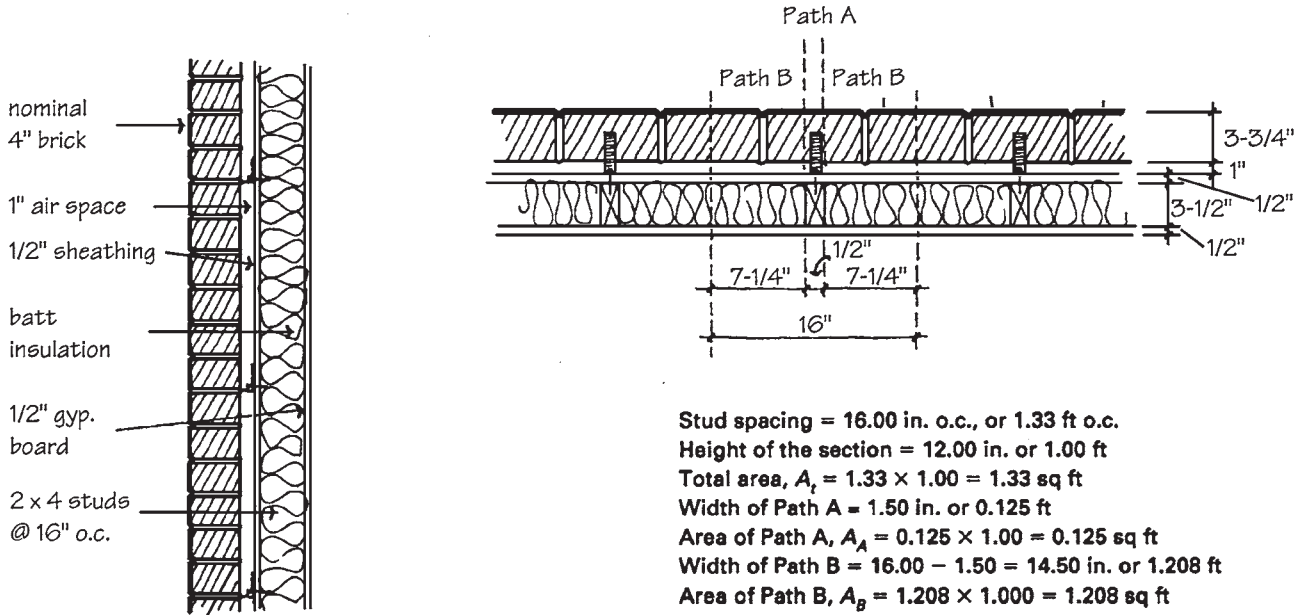

Section	C (Btu / (hr · °F · sq ft))	K (Btu · in.) / (hr · °F · sq ft)	x (in.)	C_x (Btu / (hr · °F · sq ft))	Path A $1/C_x$ (hr · °F · sq ft) / Btu	Path B $1/C_x$ (hr · °F · sq ft) / Btu
Outside air surface	6.000			6.000	0.17	0.17
4-in. nominal face brick		9.000	3.75	2.400	0.42	0.42
1-in. airspace	1.030			1.030	0.97	0.97
Exterior fiberboard sheathing	0.760			0.760	1.32	1.32
2-in. x 4-in. wood stud		0.800	3.50	0.229	4.37	
3½-in. batt insulation						11.00
½-in. gypsum wall-board	2.250			2.250	0.45	0.45
Inside air surface	1.470			1.470	0.68	0.68
					$R_A = 8.38$	$R_B = 15.01$
						$U_B = 0.067$

$R_A/A_A = 67.04 \quad R_B/A_B = 12.43$
 $1/(R_A/A_A) = 0.015 \quad 1/(R_B/A_B) = 0.080$
 $U_{avg} = [1/(R_A/A_A) + 1/(R_B/A_B)] / (A_A + A_B) = (0.015 + 0.080) / (0.125 + 1.208) = 0.071$ Btu / (hr · °F · sq ft)
 $\frac{U_{avg} - U_B}{U_B} \times 100\% = \frac{0.071 - 0.067}{0.067} \times 100\% = 6.0\%$

Figure 8-21 Thermal calculations for brick veneer/wood stud wall. (From BIA Technical Note 4 Rev.)